

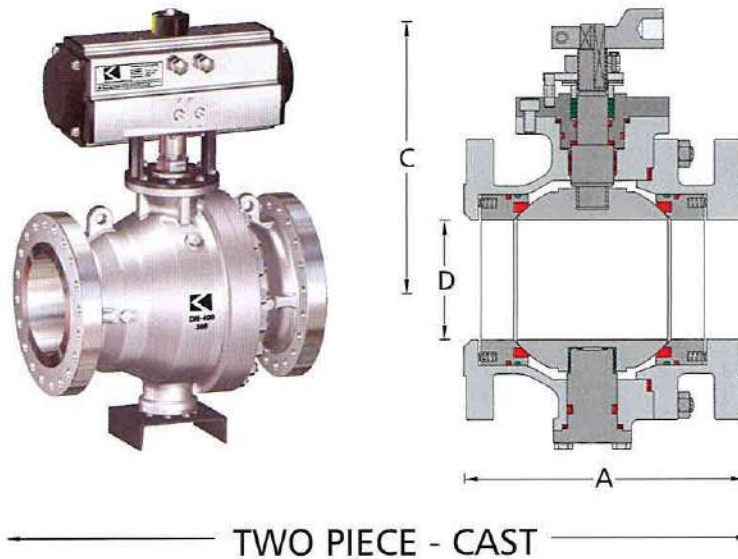

TRUNNION MOUNTED BALL VALVES

TRUNNION MOUNTED BALL VALVES



SPRING LOADED SEATS AND SEALANT INJECTION FEATURE

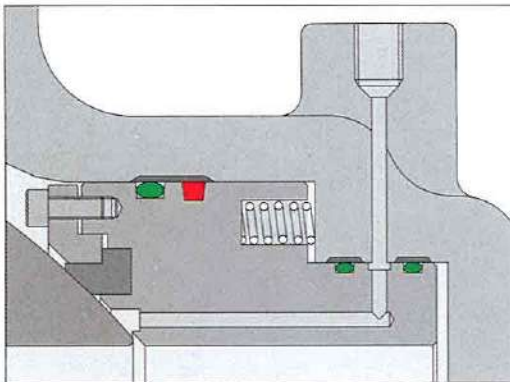

STANDARDS

DESIGN : API 6D, BS EN ISO 17292 (BS 5351), ASME B16.34, API 608

TESTING : API 6D, API 598, EN 12266-1, ASME B16.34

SERIES

'K' TR = Two Piece - Trunnion Mounted Reduced Bore

'K' TF = Two Piece - Trunnion Mounted Full Bore

APPLICATIONS

- ▶ Chemical Process Plants
- ▶ Fertilizer Plants
- ▶ Pesticides
- ▶ Caustic Chlorine Plants
- ▶ Hazardous Fluids
- ▶ Acids and Alkalies
- ▶ Oil, Gas & Petrochemical Industries

FEATURES

- Fire Safe
- Anti Static
- Anti Blow Out
- Double Block & Bleed
- Vent & Drain
- Cavity Pressure Relief
- Spring Loaded Seats
- Sealant Injection
- Fugitive Emission

MATERIALS

Body / End piece	Carbon Steel ASTM A216 Gr. WCB, A352 Gr. LCB, Stainless Steel ASTM A351 Gr. CF8 / CF8M / CN7M / Duplex
Ball	Carbon Steel ASTM A216 Gr. WCB+ENP / Stainless Steel ASTM A217 Gr. CA15 / ASTM A351 Gr. CF8 / CF8M / CN7M / Duplex
Stem / Trunnion	Stainless Steel ASTM A564 TYPE 630 (17-4PH) / ASTM A276 Type 410 Hardened / UNS S31803
Seat / Seat Insert	PTFE / RPTFE / DELRIN / NYLON / PEEK / METAL
Metal Seat	Stainless Steel ASTM A276 Type 410 Hardened / ASTM A276 Type 316 Stellite
Seat Retainer	ASTM A217 Gr. CA15 / ASTM A351 Gr. CF8 / CF8M / CN7M / Duplex
Coil Spring	INCONEL X-750
'O' Ring	Viton Gr. B
Stem Seal	Grafoil
Stem Washer	RPTFE / Grafoil
Body Seal	SPIRAL WOUND SS With Graphite filler
Trunnion / Stuffing Box Seal	PTFE / Grafoil / SPIRAL WOUND SS With Graphite filler
Stuffing Box	Carbon Steel ASTM A216 Gr. WCB, A352 Gr. LCB, Stainless Steel ASTM A351 Gr. CF8 / CF8M / CN7M / Duplex
Stuf. Box & Trunnion Bearing	SS Backed PTFE
Gland Nut	Stainless Steel
Body Stud / Nut	ASTM A193 Gr. B7, ASTM A194 Gr. 2H / ASTM A320 Gr. L7, ASTM A194 Gr. 7
Surface Protection for Carbon Steel Valves	Prime coat : Chlorine free with modified alkyd resin unobjectionable in Physiological and Toxicological respects with additional external coating of Machine varnish Smoke Gray

- Other Materials not mentioned above are available on request.
- Other Ball Materials with Electro Nickel Plating (ENP) available on request.

TWO PIECE DIMENSIONS

Dimensions are in mm (inch)

SIZE mm (Inch)	A			C				D			
	Class 150	Class 300	Class 600	Class 150		Class 300		Class 600			
				RB	FB	RB	FB	RB	FB		
50 (2)	178 (7.0)	216 (8.5)	292 (11.5)	100 (3.9)	135 (5.3)	170 (6.7)	135 (5.3)	140 (5.5)	180 (7.1)	38 (1.5)	50 (2.0)
65 (2 1/2)	190 (7.5)	241 (9.5)	330 (13.0)	135 (5.3)	155 (6.1)	185 (7.3)	155 (6.1)	180 (7.1)	190 (7.5)	50 (2.0)	62 (2.4)
80 (3)	203 (8.0)	283 (11.1)	356 (14.0)	150 (5.9)	170 (6.7)	210 (8.3)	170 (6.7)	190 (7.5)	210 (8.3)	55 (2.2)	76 (3.0)
100 (4)	229 (9.0)	305 (12.0)	432 (17.0)	170 (6.7)	205 (8.1)	230 (9.1)	512 (20.2)	420 (16.5)	585 (23.0)	76 (3.0)	98 (3.9)
150 (6)	267 ¹⁾ (10.5)	403 (15.9)	559 (22.0)	205 (8.1)	525 (20.7)	675 (26.6)	610 (24.0)	585 (23.0)	685 (27.0)	98 (3.9)	150 (5.9)
200 (8)	292 ¹⁾ (10.5)	502 (19.8)	660 (26.0)	490 (19.3)	675 (26.6)	745 (29.3)	684 (26.9)	685 (27.0)	895 (35.2)	150 (5.9)	200 (7.9)
250 (10)	330 ¹⁾ (13.0)	568 (22.4)	787 (31.0)	630 (24.8)	695 (27.4)	738 (29.0)	740 (29.1)	905 (35.6)	960 (37.8)	187 (7.4)	252 (9.9)
300 (12)	356 ¹⁾ (14.0)	648 (25.5)	838 (33.0)	700 (27.6)	755 (29.7)	810 (31.9)	808 (31.8)	975 (38.4)	980 (38.6)	228 (9.0)	305 (12.0)
350 (14)	686 (27.0)	762 (30.0)	889 (35.0)	725 (28.5)	865 (34.1)	855 (33.7)	879 (34.6)	995 (39.2)	1050 (41.3)	266 (10.4)	335 (13.2)
400 (16)	762 (30.0)	838 (33.0)	991 (39.0)	810 (31.9)	935 (36.8)	950 (37.4)	968 (38.1)	1050 (41.3)	1125 (44.3)	305 (12.0)	385 (15.2)
450 (18)	864 (34.0)	914 (36.0)	1092 (43.0)	980 (38.6)	1105 (43.5)	1025 (40.4)	1092 (43.0)	1075 (42.3)	1200 (47.2)	335 (13.2)	436 (17.2)
500 (20)	914 (36.0)	991 (39.0)	1194 (47.0)	1050 (41.3)	1180 (46.5)	1085 (42.7)	1220 (48.0)	1125 (44.3)	1350 (53.1)	385 (15.2)	487 (19.2)
600 (24)	1067 (42.00)	1143 (45.0)	1397 (55.0)	1190 (46.9)	1420 (55.9)	1165 (45.9)	1340 (52.8)	1350 (53.1)	1450 (57.1)	487 (19.2)	589 (23.2)
750 (30)	1295 (51.0)	1397 (55.0)	1651 (65.0)	1450 (57.1)	1650 (65.0)	1550 (61.0)	1800 (70.9)	1580 (62.2)	1650 (65.0)	633 (24.9)	735 (28.9)

Dimensions are in mm (inch)

SIZE mm (Inch)	A		C				D	
	Class		Class 900		Class 1500			
	900	1500	RB	FB	RB	FB	RB	FB
50 (2)	368 (14.5)	368 (14.5)	247 (9.7)	450 (17.7)	247 (9.7)	450 (17.7)	38 (1.5)	50 (2.0)
65 (2 1/2)	419 (16.5)	419 (16.5)	425 (16.7)	475 (18.7)	425 (16.7)	475 (18.7)	50 (2.0)	62 (2.4)
80 (3)	381 (15.0)	470 (18.5)	450 (17.7)	575 (22.6)	550 (21.7)	650 (25.6)	62 (2.4)	76/74 ²⁾ (3.0/2.9)
100 (4)	457 (18.0)	546 (21.5)	457 (18.0)	600 (23.6)	650 (25.6)	725 (28.5)	76/74 ²⁾ (3.0/2.9)	100 (3.9)
150 (6)	610 (24.0)	705 (27.8)	575 (22.6)	750 (29.5)	725 (28.5)	900 (35.4)	100 (3.9)	150/144 ²⁾ (5.9/5.7)
200 (8)	737 (29.0)	832 (32.8)	730 (28.7)	850 (33.5)	900 (35.4)	950 (37.4)	150/144 ²⁾ (5.9/5.7)	201/192 ²⁾ (7.9/7.6)
250 (10)	838 (33.0)	991 (39.0)	810 (31.9)	950 (37.4)	950 (37.4)	1075 (42.3)	201/192 ²⁾ (7.9/7.6)	252/239 ²⁾ (9.9/9.4)
300 (12)	965 (38.0)	1130 (44.5)	870 (34.3)	1150 (45.3)	1075 (42.3)	1225 (48.2)	252/239 ²⁾ (9.9/9.4)	305/287 ²⁾ (12.0/11.3)
350 (14)	1029 (40.5)	-	975 (38.4)	1125 (44.3)	-	-	252 (9.9)	322 (12.7)
400 (16)	1130 (44.5)	-	1200 (47.2)	1325 (52.2)	-	-	305 (12.0)	373 (14.7)

• RB = REDUCED BORE • FB = FULL BORE

1) Long Pattern for Full Bore & Sealant Injection System. 2) Dimension 'D' for Class 1500. ■ Lever Operation for size 50mm (2") to 100mm (4") Class 150 & 300, size 50mm (2") to 80mm (3") Class 600 & size 50mm (2") Class 1500. ■ Rest sizes Worm Gear Operated. ■ Flanged Ends according to ASME B16.5; other drillings on request. ■ Butt Weld Ends according to ASME B16.25. ■ Please Specify Working Pressure, Temperature & Service conditions. ■ Valves can be supplied with Padlock, Electric, Pneumatic or Gear Actuators & other accessories like Limit Switch, Solenoid Valve, Air Filter Regulator, Positioner etc.

VALVE WEIGHTS

TWO PIECE - CAST VALVES

SIZE mm (Inch)	Weights in Kg (lbs) approx									
	Class 150		Class 300		Class 600		Class 900		Class 1500	
	RB	FB	RB	FB	RB	FB	RB	FB	RB	FB
50 (2)	11 (24)	15 (33)	15 (33)	19 (42)	24 (53)	34 (75)	38 (84)	52 (115)	38 (84)	52 (115)
65 (2 1/2)	18 (40)	22 (49)	26 (57)	34 (75)	37 (82)	48 (106)	75 (165)	90 (198)	75 (165)	90 (198)
80 (3)	28 (62)	34 (75)	38 (84)	43 (95)	52 (115)	72 (159)	105 (232)	145 (320)	135 (298)	220 (485)
100 (4)	38 (84)	56 (123)	54 (119)	62 (137)	96 (212)	138 (304)	200 (441)	250 (551)	300 (661)	355 (783)
150 (6)	60 (132)	126 (278)	118 (260)	182 (401)	183 (403)	310 (683)	315 (695)	395 (871)	355 (783)	450 (992)
200 (8)	135 (298)	210 (463)	210 (463)	298 (657)	360 (794)	446 (983)	580 (1279)	685 (1510)	650 (1433)	775 (1708)
250 (10)	201 (443)	282 (622)	360 (794)	435 (959)	560 (1235)	790 (1742)	820 (1808)	980 (2160)	890 (1962)	1125 (2480)
300 (12)	270 (595)	398 (877)	496 (1094)	525 (1157)	850 (1874)	968 (2134)	1220 (2690)	1375 (3031)	1250 (2756)	1580 (3483)
350 (14)	410 (904)	554 (1221)	660 (1455)	890 (1962)	920 (2028)	1290 (2844)	1490 (3284)	1650 (3638)	-	-
400 (16)	550 (1213)	898 (1980)	854 (1883)	1190 (2624)	1310 (2888)	1710 (3770)	1620 (3572)	1880 (4145)	-	-
450 (18)	646 (1424)	1090 (2403)	1060 (2337)	1440 (3175)	1510 (3329)	2200 (4850)	-	-	-	-
500 (20)	960 (2116)	1340 (2954)	1335 (2943)	1555 (3428)	2050 (4519)	2900 (6393)	-	-	-	-
600 (24)	1450 (3197)	2050 (4520)	2450 (5401)	2800 (6173)	3250 (7165)	4600 (10141)	-	-	-	-
750 (30)	2000 (4409)	3200 (7055)	3020 (6658)	4100 (9039)	-	-	-	-	-	-

TECHNICAL DATA

Cv VALUE

SIZE mm (Inch)	Class 150		Class 300		Class 600		Class 900		Class 1500	
	RB	FB	RB	FB	RB	FB	RB	FB	RB	FB
50 (2)	140	500	140	420	135	350	125	320	125	320
65 (2 1/2)	170	880	170	830	160	805	150	790	150	790
80 (3)	220	1390	210	1050	190	1000	185	910	180	820
100 (4)	630	2550	600	2000	560	1850	505	1760	500	1610
150 (6)	925	5249	910	5186	800	4400	730	4300	730	4080
200 (8)	2500	10750	2498	10262	2150	8450	2010	8400	2005	7980
250 (10)	5000	17775	4990	17220	4500	14250	4160	14160	4150	13020
300 (12)	8400	26750	8390	25950	8000	22790	7300	21230	7280	19610
350 (14)	14080	32600	14040	30900	13990	28600	13920	26600	-	-
400 (16)	14780	44700	14750	42600	14720	39250	14690	36600	-	-
450 (18)	20840	58500	20820	56450	20750	52000	-	-	-	-
500 (20)	28100	76000	28000	72700	27850	70500	-	-	-	-
600 (24)	29000	113500	28850	109450	28750	99000	-	-	-	-
750 (30)	-	179300	-	171700	-	158900	-	-	-	-



KHIMJI FLOW EQUIPMENTS PVT. LTD.

Khimji Flow Equipments Private Limited.
Block NO. 67/E 67/F, Tarihal Revadihal Road,
Revadihal Village Hubli - 580 026.
E : info@kfel.com, W : www.kfel.com